

moteur pas à pas L298

L298



Programmer le Driver Moteur L298N (double pont en H)



Carte de contrôle des moteurs (L298N – «double pont en H») :

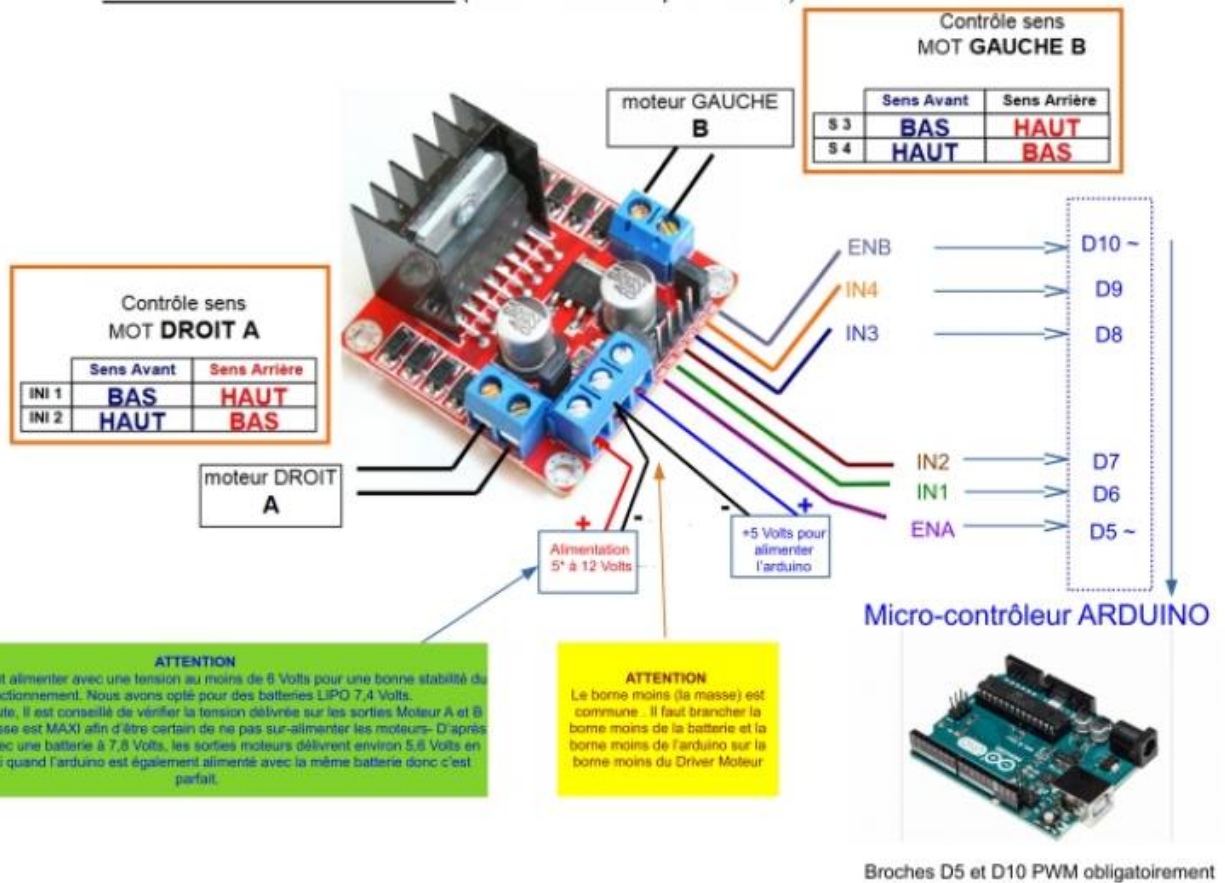



fritzing

TB6560

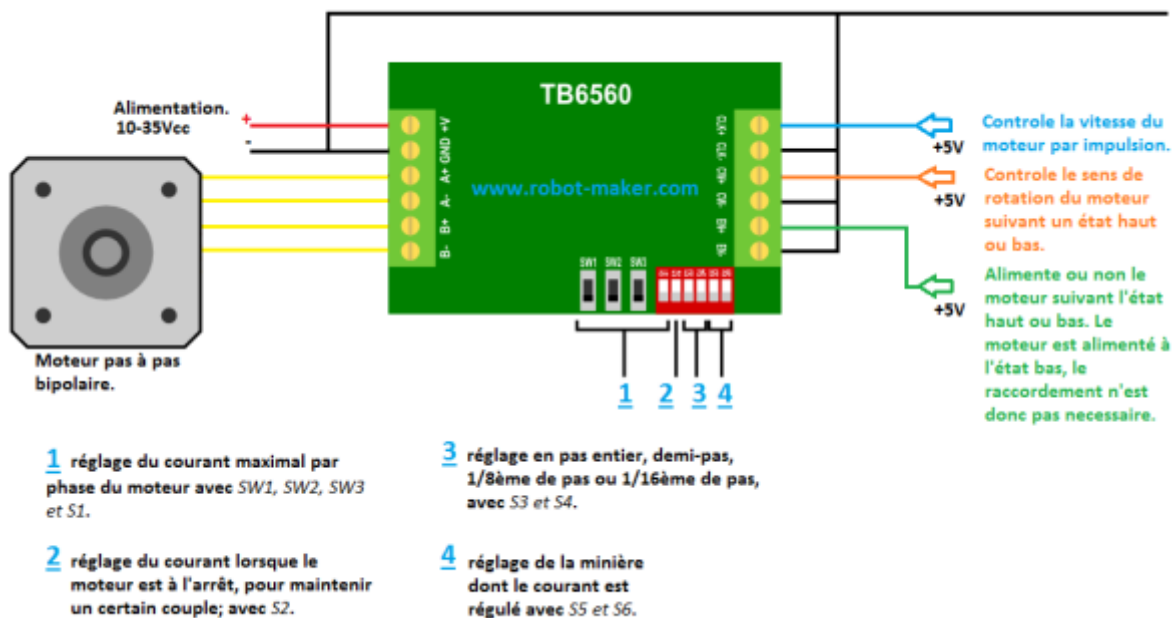

From: <https://www.magenealogie.chanterie37.fr/www/fablab37110/> - Castel'Lab le Fablab MJC de Château-Renault

Permanent link: <https://www.magenealogie.chanterie37.fr/www/fablab37110/doku.php?id=start:arduino:moteur:paspas&rev=1738435322>

Last update: 2025/02/01 19:42

