

## Tutoriels MAX7219 avec matrice 8X8



### Liens web tuto MAX7219

- [Montage Kit MAX7219 EN](#)
- [Montage Kstart:arduino:max7219:FRit MAX7219 FR](#)
- [Concevez des matrices de LED](#)
- [Tuto MAX7219 Arduino](#)
- [Matrice 8X8](#)
- [Tutoriel Arduino - MAX7219 Afficheur 8X8 LED](#)
- [MAX 7219](#)
- [LED Matrix Kit](#)
- [64 LEDS et MAX7219](#)
- [MAX7219 avec 4 matrices de LEDS 8X8 en cascade](#)
  - [Matrice LEDS 5 fois 8x8](#)
- [LEDS 8X8 par internet](#)
- [Une Video](#)

### Programmes

#### Préparation Logiciels



Utiliser ou télécharger la dernière version de [l'IDE Arduino](#)

Le diagramme de synchronisation pour Max7219 et son format de données série sont joints ci-

dessous avec ses caractéristiques électroniques.

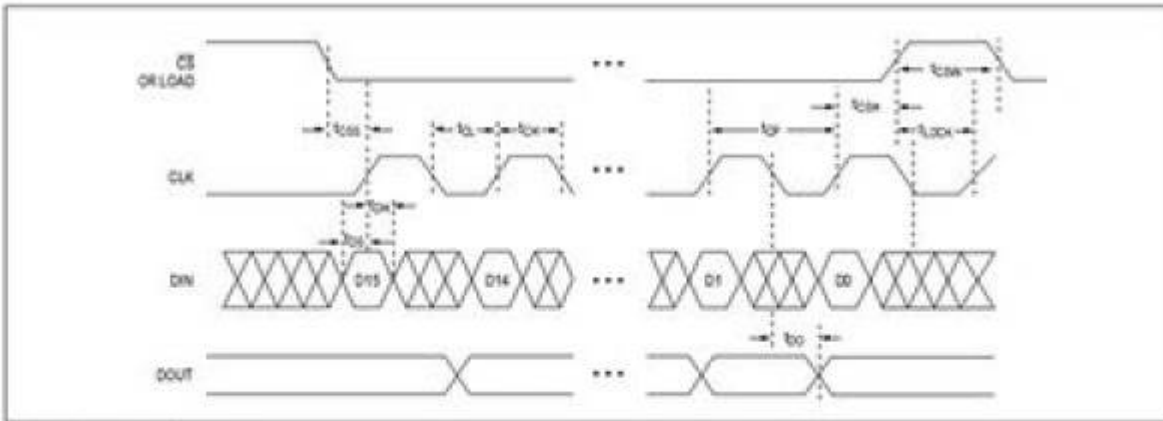

Figure 1. Timing Diagram

Table 1. Serial-Data Format (16 Bits)

D15	D14	D13	D12	D11	D10	D9	D8	D7	D6	D5	D4	D3	D2	D1	D0
X	X	X	X	ADDRESS				MSB	DATA						LSB

**ELECTRICAL CHARACTERISTICS (continued)**

(V+ = 5V ± 10%, RSET = 9.53kΩ ± 1%, TA = TMIN to TMAX, unless otherwise noted.)

PARAMETER	SYMBOL	CONDITIONS	MIN	TYP	MAX	UNITS
<b>LOGIC INPUTS</b>						
Input Current DIN, CLK, LOAD, CS	I <sub>IN</sub> , I <sub>IL</sub>	V <sub>IN</sub> = 0V or V+	-1		1	μA
Logic High Input Voltage	V <sub>IH</sub>		3.5			V
Logic Low Input Voltage	V <sub>IL</sub>				0.8	V
Output High Voltage	V <sub>OH</sub>	DOUT, I <sub>SOURCE</sub> = -1mA	V+ - 1			V
Output Low Voltage	V <sub>OL</sub>	DOUT, I <sub>SENK</sub> = 1.6mA			0.4	V
Hysteresis Voltage	ΔV <sub>I</sub>	DIN, CLK, LOAD, CS		1		V
<b>TIMING CHARACTERISTICS</b>						
CLK Clock Period	t <sub>CP</sub>		100			ns
CLK Pulse Width High	t <sub>CH</sub>		50			ns
CLK Pulse Width Low	t <sub>CL</sub>		50			ns
CS Fall to SCLK Rise Setup Time (MAX7221 only)	t <sub>CS<sub>S</sub></sub>		25			ns
CLK Rise to CS or LOAD Rise Hold Time	t <sub>CSH</sub>		0			ns
DIN Setup Time	t <sub>CS</sub>		25			ns
DIN Hold Time	t <sub>DH</sub>		0			ns
Output Data Propagation Delay	t <sub>DO</sub>	C <sub>LOAD</sub> = 50pF			25	ns
Load-Rising Edge to Next Clock Rising Edge (MAX7219 only)	t <sub>DOCK</sub>		50			ns
Minimum CS or LOAD Pulse High	t <sub>CSW</sub>		50			ns
Data-to-Segment Delay	t <sub>DSPO</sub>				2.25	ms

Un programme de test sans librairie à inclure

[exemple\\_code\\_MAX7219.ino](#)

```

unsigned char i;
unsigned char j;
/*Port Definitions*/
    
```

```

int Max7219_pinCLK = 10;
int Max7219_pinCS = 9;
int Max7219_pinDIN = 8;

unsigned char displ[38][8]={
{0x3C,0x42,0x42,0x42,0x42,0x42,0x42,0x3C},//0
{0x10,0x18,0x14,0x10,0x10,0x10,0x10,0x10},//1
{0x7E,0x2,0x2,0x7E,0x40,0x40,0x40,0x7E},//2
{0x3E,0x2,0x2,0x3E,0x2,0x2,0x3E,0x0},//3
{0x8,0x18,0x28,0x48,0xFE,0x8,0x8,0x8},//4
{0x3C,0x20,0x20,0x3C,0x4,0x4,0x3C,0x0},//5
{0x3C,0x20,0x20,0x3C,0x24,0x24,0x3C,0x0},//6
{0x3E,0x22,0x4,0x8,0x8,0x8,0x8,0x8},//7
{0x0,0x3E,0x22,0x22,0x3E,0x22,0x22,0x3E},//8
{0x3E,0x22,0x22,0x3E,0x2,0x2,0x2,0x3E},//9
{0x8,0x14,0x22,0x3E,0x22,0x22,0x22,0x22},//A
{0x3C,0x22,0x22,0x3E,0x22,0x22,0x3C,0x0},//B
{0x3C,0x40,0x40,0x40,0x40,0x40,0x3C,0x0},//C
{0x7C,0x42,0x42,0x42,0x42,0x42,0x7C,0x0},//D
{0x7C,0x40,0x40,0x7C,0x40,0x40,0x40,0x7C},//E
{0x7C,0x40,0x40,0x7C,0x40,0x40,0x40,0x40},//F
{0x3C,0x40,0x40,0x40,0x40,0x44,0x44,0x3C},//G
{0x44,0x44,0x44,0x7C,0x44,0x44,0x44,0x44},//H
{0x7C,0x10,0x10,0x10,0x10,0x10,0x10,0x7C},//I
{0x3C,0x8,0x8,0x8,0x8,0x8,0x48,0x30},//J
{0x0,0x24,0x28,0x30,0x20,0x30,0x28,0x24},//K
{0x40,0x40,0x40,0x40,0x40,0x40,0x40,0x7C},//L
{0x81,0xC3,0xA5,0x99,0x81,0x81,0x81,0x81},//M
{0x0,0x42,0x62,0x52,0x4A,0x46,0x42,0x0},//N
{0x3C,0x42,0x42,0x42,0x42,0x42,0x42,0x3C},//O
{0x3C,0x22,0x22,0x22,0x3C,0x20,0x20,0x20},//P
{0x1C,0x22,0x22,0x22,0x22,0x26,0x22,0x1D},//Q
{0x3C,0x22,0x22,0x22,0x3C,0x24,0x22,0x21},//R
{0x0,0x1E,0x20,0x20,0x3E,0x2,0x2,0x3C},//S
{0x0,0x3E,0x8,0x8,0x8,0x8,0x8,0x8},//T
{0x42,0x42,0x42,0x42,0x42,0x42,0x22,0x1C},//U
{0x42,0x42,0x42,0x42,0x42,0x42,0x24,0x18},//V
{0x0,0x49,0x49,0x49,0x49,0x2A,0x1C,0x0},//W
{0x0,0x41,0x22,0x14,0x8,0x14,0x22,0x41},//X
{0x41,0x22,0x14,0x8,0x8,0x8,0x8,0x8},//Y
{0x0,0x7F,0x2,0x4,0x8,0x10,0x20,0x7F},//Z
};

void Write_Max7219_byte(unsigned char DATA)
{
    unsigned char i;
    digitalWrite(Max7219_pinCS,LOW);
    for(i=8;i>=1;i--)
    {

```

```
        digitalWrite(Max7219_pinCLK,LOW);
        digitalWrite(Max7219_pinDIN,DATA&0x80);// Extracting a bit
data
        DATA = DATA<<1;
        digitalWrite(Max7219_pinCLK,HIGH);
    }
}

void Write_Max7219(unsigned char address,unsigned char dat)
{
    digitalWrite(Max7219_pinCS,LOW);
    Write_Max7219_byte(address);           //address=code of LED
    Write_Max7219_byte(dat);             //data=figure on LED
    digitalWrite(Max7219_pinCS,HIGH);
}

void Init_MAX7219(void)
{
    Write_Max7219(0x09, 0x00);           //decoding =BCD
    Write_Max7219(0x0a, 0x03);           //brightness
    Write_Max7219(0x0b, 0x07);           //scanlimit=8 LEDs
    Write_Max7219(0x0c, 0x01);           //power-down mode=0=normal mode=1
    Write_Max7219(0x0f, 0x00);           //test display=1=EOT=display=0
}

void setup()
{
    pinMode(Max7219_pinCLK,OUTPUT);
    pinMode(Max7219_pinCS,OUTPUT);
    pinMode(Max7219_pinDIN,OUTPUT);
    delay(50);
    Init_MAX7219();
}

void loop()
{
    for(j=0;j<38;j++)
    {
        for(i=1;i<9;i++)
            Write_Max7219(i,displ[j][i-1]);
        delay(500);
    }
}
```

## Programmes avec librairies à inclure

- afficheur8x8.zip
- max7219\_dot\_matrix\_scroll\_text.ino.zip
  - web-scroll-matrix-master.zip
  - max7219\_100.ino.tar.gz

## Librairies

Différentes librairies à tester

- ledcontrol.zip
- ledcontrol-master.zip
- maxmatrix.zip

Une librairie pour les matrices en cascade ( à essayer ...)

- ledcontrolms\_f79uc7xhkcyjmgv.zip

Une autre librairie mais pour le Raspberry ( A voir lors d'une autre soirée ...)

- luma.led\_matrix-master\_raspberry.zip
- On peut y voir une demo en image animée...

## Pour la création de codes pour matrices de LEDs

Envoyer par Fernand

### [8x8 Matrix Character Creator](#)

Pour la création de caractères 8x8 sur la matrice de LEDs

- [Leds Matrice editor](#)
- Le programme qui va avec :
- [Programme pour matrice](#)

Toujours envoyer par Fernand : un programme de test, ne pas oublier d'inclure les 2 librairies ci-dessous

### [Matrix 32x8 Max7219](#)



- exemple 002 programme 32X8
  - Librairie Adafruit\_gfx
  - Librairie Max72xx

[exemple\\_002\\_code\\_max7219\\_32X8.ino](#)

```
include SPI.h
#include Adafruit_GFX.h
#include Max72xxPanel.h

int pinCS = 10; // Attach CS to this pin, DIN to MOSI and CLK to SCK
                (cf http://arduino.cc/en/Reference/SPI )
int numberOfHorizontalDisplays = 1;
int numberOfVerticalDisplays = 4;

Max72xxPanel matrix = Max72xxPanel(pinCS, numberOfHorizontalDisplays,
numberOfVerticalDisplays);

String tape = "Ayo belajar Arduino bersama DA Electronics";
int wait = 50; // In milliseconds

int spacer = 1;
int width = 5 + spacer; // The font width is 5 pixels

void setup() {

matrix.setIntensity(7); // Use a value between 0 and 15 for brightness

// Adjust to your own needs
matrix.setRotation(matrix.getRotation() + 1 ); // The first display is
position upside down
// matrix.setRotation(1, 1); // The first display is position upside
down
}

void loop() {

for ( int i = 0 ; i < width * tape.length() + matrix.width() - 1 -
spacer; i++ ) {
```

```
matrix.fillScreen(LOW);

int letter = i / width;
int x = (matrix.width() - 1) - i % width;
int y = (matrix.height() - 8) / 2; // center the text vertically

while ( x + width - spacer >= 0 && letter >= 0 ) {
  if ( letter < tape.length() ) {
    matrix.drawChar(x, y, tape[letter], HIGH, LOW, 1);
  }

  letter--;
  x -= width;
}

matrix.write(); // Send bitmap to display

delay(wait);
}
```

From:

<https://www.magenealogie.chanterie37.fr/www/fablab37110/> - **Castel'Lab le Fablab MJC de Château-Renault**

Permanent link:

<https://www.magenealogie.chanterie37.fr/www/fablab37110/doku.php?id=start:arduino:max7219>

Last update: **2025/07/24 16:21**

